

1- Ventana de rebatir de 1 hoja

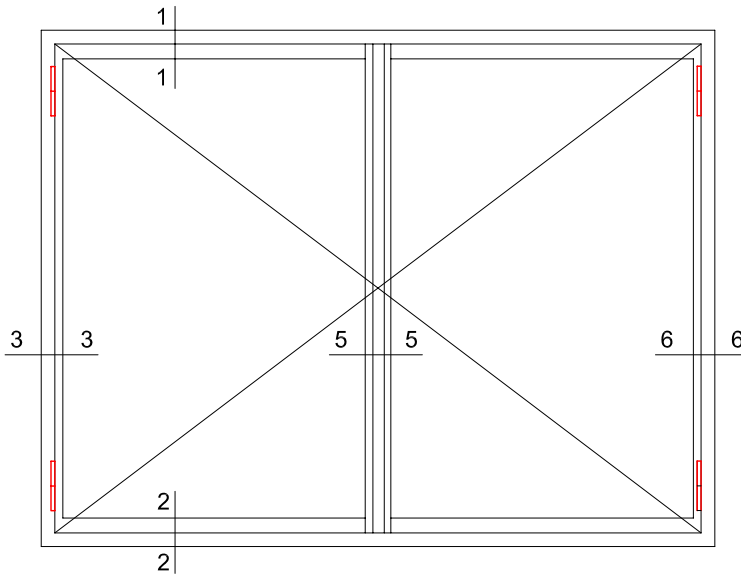

2- Ventana de rebatir de 2 hojas

Dimensiones de corte de perfiles

Cantidad		Perfil N°	Denominación	Medida (mm)	Corte
1	2				
2		MT-0902	Zócalo / Cabezal	A-112	90-90
	4	MT-0902	Zócalo / Cabezal	(A/2)-87	90-90
2	2	MT-0967	Marco simple de 31mm	A	45-45
2	2	MT-0967	Marco simple de 31mm	H	45-45
2	4	MT-0976	Parante hoja	H-52	90-90
	2	MT-0932	Encuentro central	H-52	90-90

